

Engine	Shangchai SC8D190G2B
Rated Power	140 kW (190 hp) @ 2,200 rpm
Nominal Amplitude Range	2.0 / 1.2 mm
Vibration Frequency Range	28 / 33 Hz
Centrifugal Force Range	400 / 280 kN
Working Width	2,130 mm
Operating Mass	20,000 kg

6620E ROLLER



TOUGH WORLD. TOUGH EQUIPMENT.

6620E SPECIFICATIONS >>>

ENGINE	
Emission Regulation	Tier 2 / Stage II
Make	Shangchai
Model	SC8D190G2B1
Rated Power	140 kW (190 hp) @ 2,200 rpm
Peak Torque	650 N·m
Number of Cylinders	6
Aspiration	Turbocharged & air-to-air inter-cooled
Cooling Type	Water

ELECTRICAL SYSTEM	
System Voltage	24 V

DRIVE TRAIN	
Theoretical Gradeability	45 %
Transmission Type	Hydrostatic
1st Maximum Speed, Fwd	4 km/h
2nd Maximum Speed, Fwd	5.5 km/h
3rd Maximum Speed, Fwd	6.5 km/h
4th Maximum Speed, Fwd	10.5 km/h
Inside Turning Radius	< 4,600 mm
Outside Turning Radius	< 7,000 mm

AXLES	
Steering System	Hydraulic
Steering Method	Articulation
Steering Angle	± 35°
Steering Relief Pressure	16 MPa
Differential Rear Type	Limited slip standard

BRAKES	
Service Brake Type	Hydraulic
Service Brake Actuation	Hydraulic
Parking Brake Actuation	Mechanical apply; Hydraulic release

TIRES	
Tire Size	23.1-26-12 PR
Tire Tread	G - 23

HYDRAULIC SYSTEM	
Main Pump Type	Piston pump + Piston pump
Main Relief Pressure	420 + 350 bar

PERFORMANCE	
Static Linear Front Drum Load	589 N/cm
Number of Vibrating Drums	1
Nominal Amplitude Range	2.0 / 1.2 mm
Vibration Frequency Range	28 / 33 Hz
Centrifugal Force Range	400 / 280 kN
Number of Amplitude Settings	2

OPERATING MASS	
Operating Mass with Ballast	20,000 kg
Mass on Vibrating Drum	13,200 kg
Mass on Drive Axle	6,800 kg

SERVICE CAPACITIES	
Fuel Tank	373 L
Engine Oil	19 L
Cooling System	32 L

OPTIONAL EQUIPMENT	
Padfoot Drum Segment Kit (PDH)	

DIMENSIONS	
A Overall Length	6,450 mm
B Overall Width	2,400 mm
C Drum Width	2,130 mm
D Drum Diameter	1,600 mm
E Drum Thickness	45 mm
F Wheelbase	3,250 mm
G Min. Ground Clearance	440 mm
H Overall Height	3,050 mm

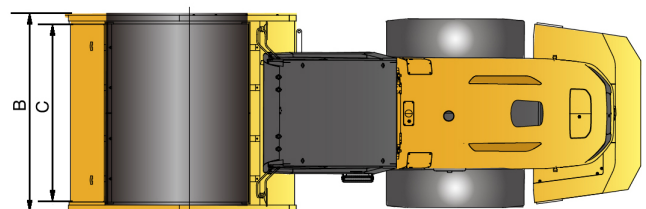
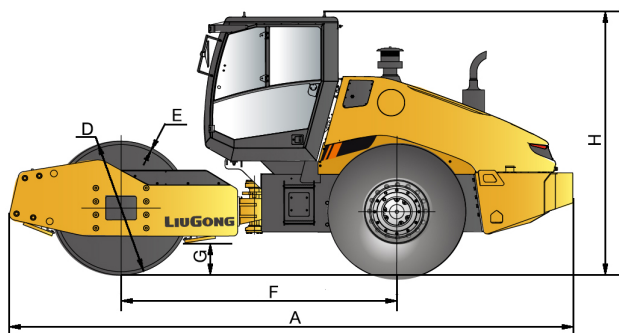

Guangxi Liugong Machinery Co., Ltd.

No. 1 Liutai Road, Liuzhou, Guangxi 545007, PR China
T: +86 772 3886124 E: overseas@liugong.com
www.liugong.com

Specifications and designs are subject to change without notice. Machines shown may include optional equipment.

02/2018 Designed by Liugong