



Engine	Cummins QSL9.3
Rated Power	190 kW (255 hp / 258 ps) @ 2,200 rpm
Net Power	178 kW (239 hp / 242 ps) @ 2,200 rpm
Operating Weight	23,474 kg
Standard Bucket Size	4.2 m ³
Standard Breakout Force	200 kN
Standard Dump Clearance	3,105 mm

870H MAX WHEEL LOADER

870H MAX SPECIFICATIONS >>>

ENGINE

Emission Regulation	Tier 3 / Stage IIIA
Manufacturer	Cummins
Model	QSL9.3
Rated Power	190 kW (255 hp / 258 ps) @ 2,200 rpm
Net Power	178 kW (239 hp / 242 ps) @ 2,200 rpm
Peak Torque	1,187 N · m @ 1,300 rpm
Displacement	9.3 L
Number of Cylinder	6
Aspiration	Turbocharged & Air-to-air intercooled

TRANSMISSION

Transmission Type	Countershaft, power shift
Torque Converter	Single stage, three elements
Maximum Travel Speed, fwd	36 km/h
Maximum Travel Speed, rev	24.2 km/h
Number of Speed, fwd	4
Number of Speed, Rev	3

AXLES

Type	Wet
Differential Front Type	Conventional
Differential Rear Type	Conventional
Axle Oscillation	±10°

STEERING

Steering Configuration	Articulated
Steering Relief Pressure	21 MPa

BRAKES

Service Brake Type	Full hydraulic
Service Brake Actuation	Hydraulic
Parking Brake Type	Drum
Parking Brake Actuation	Electro-hydraulic control

HYDRAULIC SYSTEM

Main Pump Type	Gear+Piston
Main Relief Pressure	25 MPa
Raise	5.2 s
Dump Time	1.3 s
Float Down Time	3 s
Fastest Total Cycle Time	9.5 s

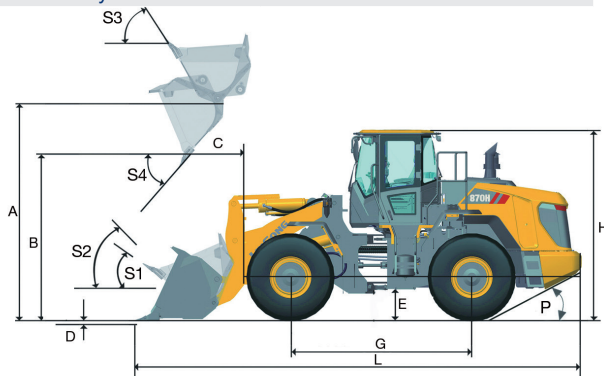

LOADER ARM PERFORMANCE

Tipping Load - Straight	19,895 kg
Tipping Load - Full Turn	16,995 kg
Bucket Breakout Force	200 kN
A Maximum Hinge Pin Height	4,460 mm
B Dump Clearance at Full Height Discharge	3,105 mm
C Dump Reach at Full Height Discharge	1,320 mm
D Maximum Digging Depth, Bucket Level	69 mm
S ₁ Bucket Rollback at Ground Level	44°
S ₂ Bucket Rollback at Carry	49°
S ₃ Bucket Rollback at Maximum Height	60.7°
S ₄ Maximum Dump Angle at Full Height	45°

BUCKET PERFORMANCE

Reference Bucket	3.0 - 7.0 m ³
------------------	--------------------------

DIMENSIONS

E Ground Clearance	460 mm
G Wheelbase	3,550 mm
H Cab Height	3,550 mm
J Wheel Tread	2,280 mm
K Width Over Tires	2,980 mm
L Length with Bucket Down	8,679 mm
M Turn Angle, Either Side	38°
P Rear Angle of Departure	29°
R ₁ Turning Radius, Bucket Carry	7,406 mm
R ₂ Turning Radius, Outside of Tire	6,300 mm

TIRES

Tire Size	26.5-25-28PR/TT L-3
-----------	---------------------

OPERATING WEIGHTS

Operating Weight	23,474 kg
------------------	-----------

SERVICE CAPACITY

Fuel Tank	330 L
Engine Oil	26 L
Cooling System	35 L
Hydraulic System	295 L
Transmission and Torque Converter	35 L
Axles, Each	57 L

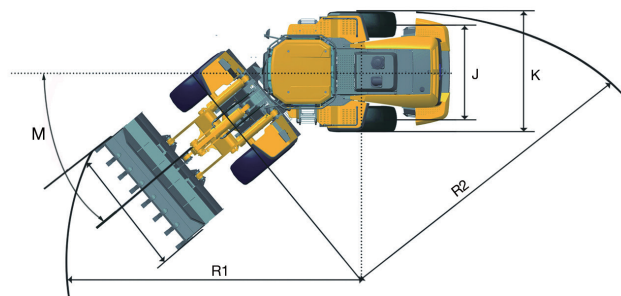

Guangxi Liugong Machinery Co., Ltd.

No. 1 Liutai Road, Liuzhou, Guangxi 545007, PR China
 T: +86 772 3886124 E: overseas@liugong.com
 www.liugong.com

Specifications and designs are subject to change without notice. Machines shown may include optional equipment. Liugong standard and optional equipment may vary from region to region. Please consult your Liugong dealer for information specific to your area. Engine power kW is converted to horsepower (1 kW=1.3596 ps and 1 kW=1.3410 hp) in this file.

05/2021 Designed by LiuGong
 Replace the previous versions of 04/2020