

LIUGONG



| | |
|-------------------------|-------------------------------------|
| Engine | Cummins B5.9 Tier 2, Stage II |
| Net Power | 102 kW (137 hp/ 139 ps) @ 1,950 rpm |
| Operating Weight | 21,500 kg |
| Bucket Capacity | 0.9 m ³ |

920E EXCAVATOR

TOUGH WORLD. TOUGH EQUIPMENT.

MAXIMIZE RETURN ON YOUR INVESTMENT

LiuGong's **customer-driven** design and **quality-focused** engineering creates lasting value that will deliver to your bottom line.

DEPENDABLE POWER

Unmatched performance driven by the Cummins B5.9 Tier 2/Stage II Engine,

IPC (INTELLIGENT POWER CONTROL)

IPC ensures the mechanical, electrical and hydraulic systems work in perfect harmony for efficient and precise control. Maximizing torque outlet with more power and breakout force.

AUTO-IDLE SPEED FUNCTION

Hydraulic signals detect activity, decreasing and increasing engine speed as required. Power is supplied only as needed, achieving optimum fuel efficiency.

VERSATILITY

Options for auxiliary hydraulic piping include bi-directional variable high flow lines, an additional line for rotating attachments and also a single acting line. The quick coupler further ensures you get the most out of your machine by easily switching between a wide range of attachments to suit any application.



BOOM AND ARM

Boom and arm structures are designed for long-term durability and resistance to bending and torsional stress. Large cross-sectional areas incorporate one-piece steel castings to provide improved strength and standard rock guard plates and vertical guards further protect the arm in rocky conditions.

UNDERCARRIAGE

Outstanding stability and durability come from an X-type reinforced frame and the long track beam and crawler system.

REAR VIEW CAMERA

Like an extra eye outside the machine, the optional rear view camera sends images to the in-cab colour LCD monitor, creating a safer working environment as you concentrate on the work at hand.

PARTS

Using genuine LiuGong parts is key to keeping your costs low and your machine in top working order. Our extensive support network is always there when you need it, to maximize your business profitability.

AFTER SALES SERVICE

As a customer of LiuGong you can feel confident that our dealers and regional offices will be there to support you with training, service and maintenance needed throughout the life of your machine.



EFFICIENCY, PRECISION & VERSATILITY

LiuGong E series excavators deliver the **perfect balance** of performance, precision and quality. The 920E Tier 2/Stage II models are powered by the latest generation, low emission Cummins B5.9 engine, with enhanced power output, **improved breakout force** and faster cycle times.

A POWERFUL ENGINE

The Cummins engine meets EPA Tier 2/ EU Stage II emissions standards, delivering the greatest possible fuel economy without compromising on power.

The B5.9 engine employs a proven cooled-EGR system, complemented by Cummins patented Turbocharger, which precisely adjusts the airflow delivered to the engine increasing performance and improving fuel economy.

ADVANCED HYDRAULIC SYSTEM

Within the advanced hydraulic system of LiuGong excavators, negative flow of the hydraulics optimizes the main control valve. This helps to maximize the cycle time of the cylinders, leading to improved efficiency and a higher rate of work completed.

The hydraulic system works efficiently in transferring engine power to the ground providing widespread control and precision.

INTELLIGENT POWER CONTROL

LiuGong's advanced Intelligent Power Control (IPC) system delivers the power you need, only when you need it, ensuring powerful performance, without excess fuel wastage.

The new-generation computer-aided IPC system harnesses the mechanical, electrical and hydraulic systems to work in perfect harmony for efficiency, precision and control. When the working load increases, engine power and hydraulic pump flow respond to meet the demands of the job.

LiuGong's six selectable working modes give you full control of the machine and enhanced performance under various operating conditions:



AUTOMATED FUNCTIONS

The machines maximize fuel economy by regulating its idle speed. If for just one second there is no hydraulic request signal detected from the joystick, the engine speed is automatically dropped by 100 rpm. If no activity is detected over three seconds the engine speed will decrease to idle. As soon as the system detects the hydraulic signal

once more, the engine will immediately return to the previous throttle speed setting.

The engine's automatic warm-up system brings it up to operating temperature quickly, further improving fuel consumption, reducing emissions, and maximizing uptime.



DESIGNED TO GET MORE DONE

The machines are designed to **get more done** in less time. Featuring a stronger boom arm and bucket breakout force, greater hydraulic flow, higher swing speeds and improved cycle times, this excavator will **power through any task** in any terrain.

POWERFUL PERFORMANCE

The Cummins B5.9 engine produces high power output. LiuGong has harnessed this power for the six working modes of the excavator. Perfectly match these work modes to the job at hand and even the least experienced of the operators will find they can work faster and complete more in less time.

OPTIMIZED HYDRAULICS

Where intelligence meets brute force. Negative flow hydraulics direct the engine's power to ensure hydraulic pump flow continually adjustable for smooth, quick and efficient operation.

Engine power and hydraulic pump flow are automatically reset to adjust for the load attachment, helping to maximize the efficiency of the machine.

IMPROVED MACHINE DESIGN

The 920E's tough and reliable structure provides increased strength, reduced wear, and improved transmission of power to the ground drive.

QUICK-CHANGE ATTACHMENTS

LiuGong quick coupler and Power Latch tilt couple make changing over attachments like buckets, breakers and shears quick and simple which maximize your uptime.

OPERATOR FRIENDLY ENVIRONMENT

Ergonomically designed controls, clear and informative displays, increased visibility, and exceptional comfort increases operator efficiency and safety. The easily accessible service points ensures important daily servicing and routine maintenance gets done.



TOUGH AND DURABLE STRUCTURES

The use of thick, high-tensile steel components, internal baffling and stress-relieved plates, make the structures on LiuGong E-series excavators **tough and durable**.

We guarantee the **quality and reliability** of our machines throughout the manufacturing process by conducting stringent tests and ultrasound inspections that detect defects well before they make it into production.



BOOM & ARM

The boom and arm structures are designed with large cross-sectional supports and incorporates one-piece steel castings. This solid engineering guarantees long-term durability and high resistance to bending and torsional stress. Standard rock-guard plates and vertical guards protect the arm in rocky digging conditions and tough environments.

UPPER STRUCTURE

The upper structure is strongly reinforced by the use of an H-beam in the high cross section of the main structure providing even weight distribution and increasing stability.

The platform's collision protection system has been welded into place to improve its strength, rigidity and overall service life.



UNDERCARRIAGE

The high-strength undercarriage of the 920E incorporates a welded X-frame construction for long life durability and is designed to perform in the most challenging applications.

A long track beam and crawler system provides greater stability when using attachments for digging and truck loading. The result is outstanding strength and durability.



SAFETY WITHOUT COMPROMISE

LiuGong's commitment to you includes an equal commitment to your **safety**. E-series excavators are equipped with all the necessary safety features to give you peace of mind and help you **focus** on the job at hand.

SAFETY STANDARDS

All LiuGong E-Series excavators come with certified ROPS (Roll Over Protection System) cabs meeting ISO safety standards. LiuGong offers FOPS (Falling Object Protection System) as an option on all E-Series excavators.

EXTENSIVE VISIBILITY

LiuGong's E-Series cabs have seven percent larger glass surface area compared to our D-Series cab. Standard rear view camera gives the operator a panoramic view, combined with optional LED work lights, provides clearer line of sight on job sites.

SAFE ENTRY

Safety rails and well-positioned anti-slip tape on the upper part of the machine make it easier and safer during machine servicing.



ALL AROUND COMFORT

In the cab, you are working in complete comfort with outstanding visibility all around. We understand how operators like to work and have designed the cab for **maximum comfort** and ultimate productivity.

AT HOME IN THE CAB

The E series cab is ROPS ISO 12117-2 certified mounted on dampener silicone to absorb noise and vibration. Wide spacious cab door swings full open to lock position. Front windshield slides up into ceiling, removable lower window, large roof skylight with sun screen.

ADVANCED CLIMATE CONTROL

Pressurized cab, advanced climate control system and front windshield defrost allow all year around operating comfort in any environment. Air is circulating through cab by ten outlets to improve air circulation.

ADJUSTABLE SEAT AND JOYSTICK CONSOLE

The adjustable seat and joystick console move independently to accommodate the operator. Increased spacing between the armrest and nine different seat adjustments allow the operator more options to all foot and hand controls for maximum comfort.



DAILY CHECKS AND MAINTENANCE SHOULDN'T BE TOUGH

LiuGong excavators have been **specifically designed** for easy service and maintenance in even the most remote and harsh environments. If servicing is easy, it gets done.

PRACTICAL SERVICING

Smart and effective design makes service and maintenance fast and simple – that's good news for operators who work in some of the toughest places on the planet. Handrails are fitted as standard on the 920E, enabling safe and easy access to the upper structure for easy engine service and maintenance.

ON BOARD MONITORING

With onboard monitoring, the operator can check the machine's vital signs without leaving his seat. Using the LCD display, the operator can easily check oil temperatures and pressure levels, receive service interval alerts and access other information that contributes to simple maintenance and servicing of the machine.



EASILY ACCESSIBLE SERVICE POINTS MAKE DAILY CHECKS FAST AND EFFECTIVE

- Easily visible hydraulic oil level gauge
- Accessible, grouped filters
- Easy to replace A/C filter next to the cab door
- Maintenance free air filter

WHERE YOU NEED US WHEN YOU NEED US

LiuGong is committed to providing **reliable** and **tough** equipment combined with dependable service to customers **across the globe**.

GLOBAL NETWORK

We offer local support through our extensive dealer network in more than 100 countries. Our dealers and customers are supported by 10 regional subsidiaries and 9 global parts centers, all offering expert training, parts and service support.

PROFESSIONAL ADVICE

No matter the job, we can help you choose the right machine, with the right specifications, options and attachments for your business. We are committed to ensure maximum uptime and lowest cost of ownership to ensure you get good profitable return from your equipment.

SERVICE AGREEMENTS

At LiuGong, we offer service agreements to support your business needs and help you take control of all your costs. Talk to us today.



SPECIFICATIONS

OPERATING WEIGHT 21,500 kg

Operating weight includes coolant, lubricants, full fuel tank, cab, standard shoes, boom, arm, bucket and operator 75 kg.

BUCKET CAPACITY 0.9 - 1.1 m³

ENGINE

Description

Cummins EPA Tier 2 / EU Stage II, inline 6-cylinder, turbocharged, mechanically controlled direct injection. Air cleaner: Cummins direct flow air filter. Cooling system: Charge air cooler

| | |
|-----------------------------------------------|--------------------------|
| Emission rating | EPA Tier 2 / EU Stage II |
| Engine manufacturer | Cummins |
| Engine model | B5.9 |
| Aspiration | Wastegate Turbo (WGT) |
| Charged air cooling | Aftercooler |
| Cooling fan drive | Direct |
| Displacement | 5.9 L |
| Rated speed | 1,950 rpm |
| Engine output - net (SAE J1349 / ISO 9249) | 102 kW (137 hp/ 139 ps) |
| Engine output - gross (SAE J1995 / ISO 14396) | 112 kW (150 hp/ 152 ps) |
| Maximum torque | 614 N·m @1,500 rpm |
| Bore × Stroke | 102 × 120 mm |

UNDERCARRIAGE

| | |
|----------------------------|----------------|
| Track shoe each side | 46 |
| Link pitch | 190 mm |
| Shoe width, triple grouser | 600/700/800 mm |
| Bottom rollers each side | 7 |
| Top rollers each side | 2 |

SWING SYSTEM

Description

Planetary gear reduction driven by high torque axial piston motor, with oil disk brake. Swing parking brake resets within five seconds after swing pilot controls return to neutral.

| | |
|--------------|------------|
| Swing speed | 12.5 rpm |
| Swing torque | 78,200 N·m |

HYDRAULIC SYSTEM

Main pump

| | |
|--------------|----------------------------------------|
| Type | Two variable displacement piston pumps |
| Maximum flow | 2 × 224 L/min |

Pilot pump

| | |
|--------------|-----------|
| Type | Gear pump |
| Maximum flow | 19 L/min |

Relief valve setting

| | |
|----------------|---------------|
| Implement | 34.3/37.3 MPa |
| Travel circuit | 34.3 MPa |
| Slew circuit | 25.5 MPa |
| Pilot circuit | 3.9 MPa |

Hydraulic cylinders

| | |
|---------------------------------|-----------------|
| Boom Cylinder – Bore × Stroke | Φ120 × 1,335 mm |
| Arm Cylinder – Bore × Stroke | Φ135 × 1,490 mm |
| Bucket Cylinder – Bore × Stroke | Φ115 × 1,120 mm |

ELECTRIC SYSTEM

| | |
|----------------|---------------|
| System Voltage | 24 V |
| Batteries | 2 × 12 V |
| Alternator | 24 V - 70 A |
| Start motor | 24 V - 7.8 kW |

SERVICE CAPACITIES

| | |
|------------------------|-------|
| Fuel tank | 420 L |
| Engine oil | 25 L |
| Final drive (each) | 5.5 L |
| Swing drive | 3.4 L |
| Cooling system | 25 L |
| Hydraulic reservoir | 210 L |
| Hydraulic system total | 330 L |

SOUND PERFORMANCE

| | |
|---------------------------------------|-----------|
| Interior Sound Power Level (ISO 6396) | 73 dB(A) |
| Exterior Sound Power Level (ISO 6395) | 103 dB(A) |

DRIVE AND BRAKES

Description

2-speed axial piston motors with oil disk brakes. Steering controlled by two hand levers with pedals.

| | |
|-------------------|---------------------------------|
| Max. travel speed | High: 5.7 km/h Low: 3.3 km/h |
| Gradeability | 35°/70% |
| Max. drawbar pull | 220 kN |

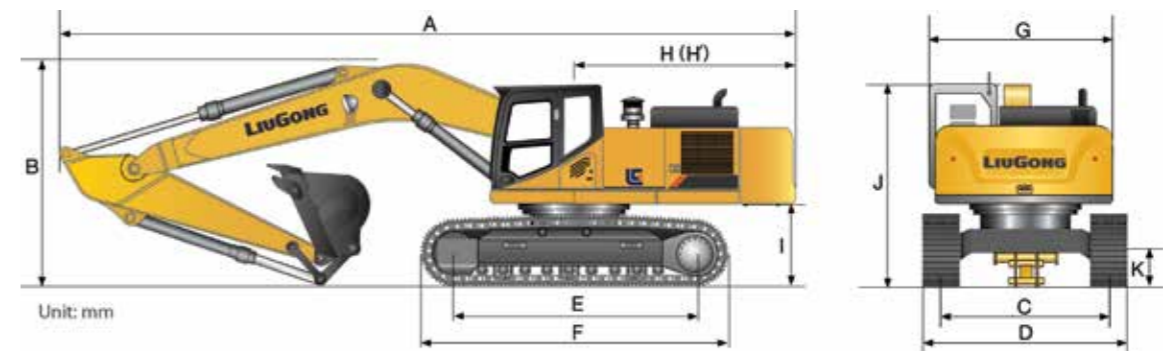

DIMENSIONS

| | |
|-------------------------------------------|---------------------|
| Boom | 5,710 mm |
| Arm Options | 2,915 mm / 2,700 mm |
| A Shipping Length | 9,540 mm |
| B Shipping Height – Top of Boom | 3,140 mm |
| C Track Gauge | 2,200 mm |
| D Undercarriage Width – with 600 mm Shoes | 2,800 mm |
| 700 mm Shoes | 2,900 mm |
| 800 mm Shoes | 3,000 mm |
| E Length to Center of Rollers | 3,370 mm |
| F Track Length | 4,160 mm |
| G Overall Width of Upper Structure | 2,740 mm |
| H Tail Swing Radius | 2,750 mm |
| I Counterweight Ground Clearance | 1,070 mm |
| J Overall Height of Cab | 3,040 mm |
| K Min. Ground Clearance | 440 mm |
| Track Shoe Width | 600 mm |

MACHINE WEIGHTS AND GROUND PRESSURE

| Shoe width | 5,710 mm boom, 2,915 mm arm, 1.0 m ³ bucket, 4,000 kg counterweight | | | 5,710 m boom, 2,700 mm arm, 1.1 m ³ bucket, 4,000 kg counterweight | | |
|------------|--------------------------------------------------------------------------------|-----------------|---------------|-------------------------------------------------------------------------------|-----------------|---------------|
| | Operating weight | Ground pressure | Overall width | Operating weight | Ground pressure | Overall width |
| 600 mm | 21,500 kg | 44.2 kPa | 2,800 mm | 21,500 kg | 44.2 kPa | 2,800 mm |
| 700 mm | 21,780 kg | 38.4 kPa | 2,900 mm | 21,780 kg | 38.4 kPa | 2,900 mm |
| 800 mm | 22,070 kg | 34.0 kPa | 3,000 mm | 22,070 kg | 34.0 kPa | 3,000 mm |

ARM DIMENSIONS

| | | |
|--------|----------|----------|
| Arm | 2,915 mm | 2,700 mm |
| Length | 3,895 mm | 3,685 mm |
| Height | 790 mm | 810 mm |
| Width | 466 mm | 466 mm |
| Weight | 1,110 kg | 1,073 kg |

Cylinder, linkage and pin included.

BOOM DIMENSIONS

| | |
|--------|----------|
| Boom | 5,710 mm |
| Length | 5,915 mm |
| Height | 1,550 mm |
| Width | 621 mm |
| Weight | 1,895 kg |

Cylinder, piping and pin included.
Boom cylinder pin excluded.



BUCKET SELECTION GUIDE

| Bucket type | Capacity | Cutting width | Weight | Teeth pcs | 5.7 m boom | |
|-------------------------|---------------------|---------------|--------|-----------|------------|-----------|
| | | | | | 2.9 m arm | 2.7 m arm |
| Heavy duty | 0.9 m ³ | 1,083 mm | 786 kg | 5 | B | B |
| General purpose | 0.95 m ³ | 1,268 mm | 769 kg | 5 | B | B |
| Heavy duty | 1 m ³ | 1,113 mm | 887 kg | 5 | B | B |
| Wide and shallow bucket | 1 m ³ | 1,227 mm | 850 kg | 5 | A | A |
| Super heavy duty | 1 m ³ | 1,280 mm | 905 kg | 5 | C | C |
| Heavy duty | 1.1 m ³ | 1,330 mm | 852 kg | 6 | B | B |

The recommendations are given as a guide only, based on typical operation conditions. Bucket capacity based on ISO 7451, heaped material with a 1:1 angle of repose.

A 1,200 - 1,300 kg/m³ (2,023 - 2,191 lbs/yd³): Coal, Caliche, Shale
 B 1,400 - 1,600 kg/m³ (2,360 - 2,697 lbs/yd³): Wet earth and clay, limestone, sandstone
 C 1,700 - 1,800 kg/m³ (2,865 - 3,034 lbs/yd³): Granite, wet sand, well blasted rock
 D 1,900 kg/m³ (3,203 lbs/yd³): Wet mud, Iron ore
 NA. Not applicable

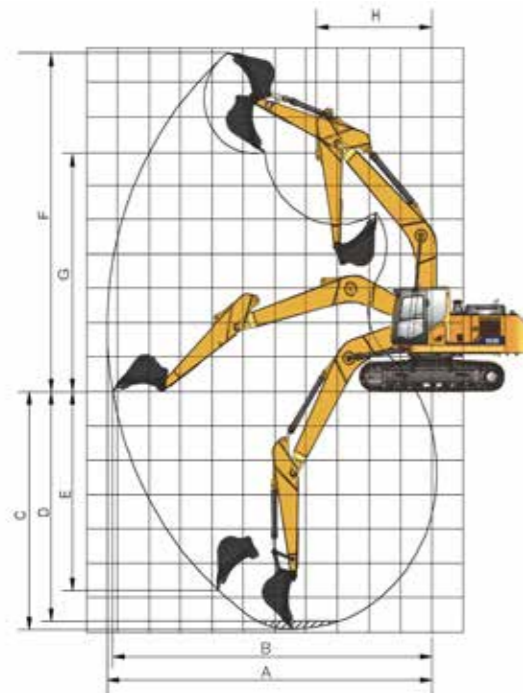

WORKING RANGE

| | | |
|------------------------------------------|------------------------|------------------------|
| Boom | 5,710 mm | |
| Arm Options | 2,915 mm | 2,700 mm |
| A. Max. Digging Reach | 9,870 mm | 9,735 mm |
| B. Max. Digging Reach on Ground | 9,685 mm | 9,550 mm |
| C. Max. Digging Depth | 6,562 mm | 6,380 mm |
| D. Max. Digging Depth, 2.44 m (8') level | 6,390 mm | 6,140 mm |
| E. Max. Vertical Wall Digging Depth | 5,080 mm | 5,040 mm |
| F. Max. Cutting Height | 9,945 mm | 9,970 mm |
| G. Max. Dumping Height | 7,170 mm | 7,200 mm |
| H. Min. Front Swing Radius | 3,090 mm | 3,120 mm |
| Bucket Digging Force (ISO) | Normal | 140 kN 140 kN |
| | Power Boost | 152 kN 152 kN |
| Arm Digging Force (ISO) | Normal | 97 kN 102 kN |
| | Power Boost | 105 kN 110.5 kN |
| Bucket Capacity | 0.9/1.0 m ³ | 1.0/1.1 m ³ |
| Bucket Tip Radius | 1,450 mm | 1,450 mm |

LIFTING CAPACITY (METRIC)

920E with 600 mm shoes, 2,915 mm arm

Conditions
 Boom length: 5,710 mm
 Arm length: 2,915 mm
 Bucket: None
 Counterweight: 4,000 kg
 Shoes: 600 mm triple grouser
 Unit: kg

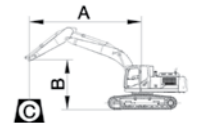

| B (m) | A (Unit: m) | | | | | | | | | | | | MAX REACH | A (m) | |
|-------|-------------|---------|---------|--------|---------|--------|--------|--------|--------|-------|--------|-------|-----------|--------|-----|
| | 3 | 4 | 5 | 6 | 7 | 8 | | | | | | | | | |
| 7 | | | | | | | 5,340* | 5,340* | | | | | 5,050* | 5,050* | 6.6 |
| 6 | | | | | | | 5,420* | 5,420* | 5,510* | 4,650 | | | 5,360* | 4,460 | 7.2 |
| 5 | | | | | 6,070* | 6,070* | 5,780* | 5,780* | 5,650* | 4,610 | | | 4,670* | 3,920 | 7.8 |
| 4 | | | 8,140* | 8,140* | 7,010* | 7,010* | 6,360* | 5,650 | 5,960* | 4,550 | 5,670* | 3,740 | 5,670* | 3,740 | 8.0 |
| 3 | | | 10,100* | 9,680 | 8,100* | 7,070 | 7,030* | 5,510 | 6,380* | 4,460 | 5,710 | 3,700 | 5,510 | 3,560 | 8.2 |
| 2 | | | 11,880* | 9,220 | 9,180* | 6,820 | 7,710* | 5,340 | 6,820* | 4,360 | 5,650 | 3,640 | 5,150* | 3,400 | 8.4 |
| 1 | | | 13,090* | 8,940 | 10,060* | 6,630 | 8,310* | 5,210 | 6,760 | 4,280 | 5,610 | 3,580 | 5,420 | 3,480 | 8.2 |
| 0 | 8,210* | 8,210* | 13,670* | 8,810 | 10,640* | 6,500 | 8,340 | 5,130 | 6,690 | 4,210 | 5,570 | 3,540 | 5,380 | 3,450 | 8.2 |
| -1 | 11,670* | 11,670* | 13,770* | 8,760 | 10,890* | 6,420 | 8,270 | 5,070 | 6,650 | 4,170 | | | 5,750 | 3,660 | 7.8 |
| -2 | 15,750* | 13,820 | 13,510* | 8,770 | 10,820* | 6,420 | 8,270 | 5,050 | 6,650 | 4,170 | | | 6,170 | 3,910 | 7.4 |
| -3 | 16,400* | 13,970 | 12,840* | 8,850 | 10,390* | 6,460 | 8,310 | 5,090 | | | | | 5,150* | 4,380 | 7.0 |
| -4 | 14,670* | 14,180 | 11,630* | 8,980 | 9,420* | 6,570 | | | | | | | 7,900* | 5,420 | 5.8 |

LIFTING CAPACITY (METRIC)

920E with 600 mm shoes, 2,700 mm arm

Conditions
 Boom length: 5,710 mm
 Arm length: 2,700 mm
 Bucket: None
 Counterweight: 4,000 kg
 Shoes: 600 mm triple grouser
 Unit: kg

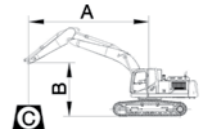

| B (m) | A (Unit: m) | | | | | | | | | | | | MAX REACH | A (m) | |
|-------|-------------|---------|---------|--------|---------|--------|--------|--------|--------|-------|--------|-------|-----------|-------|-----|
| | 3 | | 4 | | 5 | | 6 | | 7 | | 8 | | | | |
| | Cf | Cs | Cf | Cs | Cf | Cs | Cf | Cs | Cf | Cs | Cf | Cs | Cf | Cs | |
| 7 | | | | | | | 5,610* | 5,610* | | | | | | | 6.4 |
| 6 | | | | | 5,690* | 5,690* | 5,650* | 5,650* | 5,630* | 4,610 | | | 5,630* | 4,610 | 7.0 |
| 5 | | | | | 6,340* | 6,340* | 6,010* | 5,760 | 5,860* | 4,590 | | | 4,920* | 4,050 | 7.6 |
| 4 | | | 8,610* | 8,610* | 7,300* | 7,300 | 6,570* | 5,630 | 6,150* | 4,530 | 4,420* | 3,720 | 4,420* | 3,720 | 8.0 |
| 3 | | | 10,600* | 9,630 | 8,400* | 7,050 | 7,230* | 5,500 | 6,550* | 4,440 | 5,710 | 3,690 | 4,550* | 3,550 | 8.2 |
| 2 | | | 12,320* | 9,220 | 9,460* | 6,820 | 7,900* | 5,360 | 6,860 | 4,360 | 5,650 | 3,640 | 5,460 | 3,510 | 8.2 |
| 1 | | | 13,400* | 8,980 | 10,280* | 6,650 | 8,460 | 5,230 | 6,760 | 4,280 | 5,610 | 3,590 | 5,400* | 3,480 | 8.2 |
| 0 | | | 13,850* | 8,890 | 10,800* | 6,530 | 8,360 | 5,150 | 6,710 | 4,230 | 5,570 | 3,560 | 5,570 | 3,560 | 8.0 |
| -1 | 11,720* | 11,720* | 13,850* | 8,850 | 10,970 | 6,480 | 8,310 | 5,110 | 6,670 | 4,190 | | | 5,960 | 3,790 | 7.6 |
| -2 | 16,370* | 14,020 | 13,470* | 8,890 | 10,850* | 6,480 | 8,310 | 5,110 | 6,690 | 4,210 | | | 6,440 | 4,070 | 7.2 |
| -3 | 16,090* | 14,170 | 12,710* | 8,970 | 10,310* | 6,530 | 8,360 | 5,150 | | | | | 7,320 | 4,590 | 6.6 |
| -4 | 14,190* | 14,190* | 11,320* | 9,100 | 9,150* | 6,650 | | | | | | | 7,940* | 5,750 | 5.6 |

- Lifting capacity at the arm end without bucket. For lifting capacity including bucket, weight of the bucket or the bucket with quick coupler must be deducted from the lifting capacities. Lifting capacities are based on the machine standing on a firm, uniform supporting surface.
- Do not attempt to lift or hold any load that is greater than these rated values at their specified load radius and height. Weight of all accessories must be deducted from the above lifting capacities.
- The rated loads are in compliance with ISO 10567 Hydraulic Excavator Lift Capacity Rating Standard. They do not exceed 87% of hydraulic lifting capacity or 75% tipping load.
- Ratings at bucket lift hook.
- Lifting capacities are based on machine standing on level, firm and uniform ground.
- *Indicates the load is limited by hydraulic capacity rather than tipping capacity.
- Operator should be fully acquainted with the Operator's and Maintenance Instructions before operating this machine and rules for the safe operation of equipment should be adhered to at all times.





LIFTING CAPACITY (METRIC)

920E with 800 mm shoes, 2,915 mm arm

A: Load radius
B: Load point height
C: Lifting capacity
Cf: Rating over front
Cs: Rating over side

Conditions

Boom length: 5,710 mm
Arm length: 2,915 mm
Bucket: None
Counterweight: 4,000 kg
Shoes: 600 mm triple grouser
Unit: kg

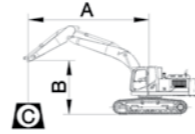

| B (m) | A (Unit: m) | | | | | | | | | | | | | | MAX REACH A (m) |
|-------|-------------|---------|---------|--------|---------|--------|--------|--------|--------|-------|--------|-------|--------|--------|--------------------|
| | 3 | | 4 | | 5 | | 6 | | 7 | | 8 | | | | |
| | Cf | Cs | Cf | Cs | Cf | Cs | Cf | Cs | Cf | Cs | Cf | Cs | Cf | Cs | |
| 7 | | | | | | | 5,340* | 5,340* | | | | | 5,050* | 5,050* | 6.6 |
| 6 | | | | | | | 5,420* | 5,420* | 5,510* | 4,820 | | | 5,360* | 4,460 | 7.2 |
| 5 | | | | | 6,070* | 6,070* | 5,780* | 5,780* | 5,650* | 4,780 | | | 4,670* | 3,920 | 7.8 |
| 4 | | | 8,140* | 8,140* | 7,010* | 7,010* | 6,360* | 5,840 | 5,960* | 4,690 | 5,670* | 3,860 | 5,670* | 3,740 | 8.0 |
| 3 | | | 10,100* | 10,000 | 8,100* | 7,300 | 7,030* | 5,690 | 6,380* | 4,610 | 5,900 | 3,820 | 5,510 | 3,560 | 8.2 |
| 2 | | | 11,880* | 9,550 | 9,180* | 7,050 | 7,710* | 5,530 | 6,820* | 4,510 | 5,840 | 3,760 | 5,150* | 3,400 | 8.4 |
| 1 | | | 13,090* | 9,270 | 10,060* | 6,860 | 8,310* | 5,400 | 6,980 | 4,420 | 5,800 | 3,720 | 5,420 | 3,480 | 8.2 |
| 0 | 8,210* | 8,210* | 13,670* | 9,130 | 10,640* | 6,730 | 8,610 | 5,300 | 6,920 | 4,360 | 5,760 | 3,690 | 5,380 | 3,450 | 8.2 |
| -1 | 11,670* | 11,670* | 13,770* | 9,070 | 10,890* | 6,670 | 8,560 | 5,260 | 6,880 | 4,320 | | | 5,750 | 3,660 | 7.8 |
| -2 | 15,750* | 14,320 | 13,510* | 9,100 | 10,820* | 6,650 | 8,550 | 5,250 | 6,880 | 4,320 | | | 6,170 | 3,910 | 7.4 |
| -3 | 16,400* | 14,470 | 12,840* | 9,180 | 10,390* | 6,710 | 8,590 | 5,280 | | | | | 5,150* | 4,380 | 7.0 |
| -4 | 14,670* | 14,670* | 11,630* | 9,310 | 9,420* | 6,800 | | | | | | | 7,900* | 5,420 | 5.8 |

920E with 800 mm shoes, 2,700 mm arm

A: Load radius
B: Load point height
C: Lifting capacity
Cf: Rating over front
Cs: Rating over side

Conditions

Boom length: 5,710 mm
Arm length: 2,700 mm
Bucket: None
Counterweight: 4,000 kg
Shoes: 600 mm triple grouser
Unit: kg

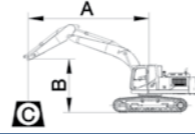

| B (m) | A (Unit: m) | | | | | | | | | | | | | | MAX REACH A (m) |
|-------|-------------|---------|---------|--------|---------|--------|--------|--------|--------|-------|--------|-------|--------|--------|--------------------|
| | 3 | | 4 | | 5 | | 6 | | 7 | | 8 | | | | |
| | Cf | Cs | Cf | Cs | Cf | Cs | Cf | Cs | Cf | Cs | Cf | Cs | Cf | Cs | |
| 7 | | | | | | | 5,610* | 5,610* | | | | | 5,110* | 5,110* | 6.4 |
| 6 | | | | | 5,690* | 5,690* | 5,650* | 5,650* | 5,630* | 4,780 | | | 5,630* | 4,610 | 7.0 |
| 5 | | | | | 6,340* | 6,340* | 6,010* | 5,940 | 5,860* | 4,750 | | | 4,920* | 4,050 | 7.6 |
| 4 | | | 8,610* | 8,610* | 7,300* | 7,300* | 6,570* | 5,820 | 6,150* | 4,690 | 4,420* | 3,840 | 4,420* | 3,720 | 8.0 |
| 3 | | | 10,600* | 9,940 | 8,400* | 7,280 | 7,230* | 5,670 | 6,550* | 4,590 | 5,900 | 3,810 | 4,550* | 3,550 | 8.2 |
| 2 | | | 12,320* | 9,550 | 9,460* | 7,050 | 7,900* | 5,530 | 6,960* | 4,510 | 5,840 | 3,760 | 5,460 | 3,510 | 8.2 |
| 1 | | | 13,400* | 9,310 | 10,280* | 6,880 | 8,470* | 5,420 | 7,000 | 4,440 | 5,800 | 3,730 | 5,400* | 3,480 | 8.2 |
| 0 | | | 13,850* | 9,210 | 10,800* | 6,780 | 8,640 | 5,340 | 6,940 | 4,380 | 5,760 | 3,700 | 5,570 | 3,560 | 8.0 |
| -1 | 11,720* | 11,720* | 13,850* | 9,180 | 10,980* | 6,730 | 8,600 | 5,300 | 6,900 | 4,360 | | | 5,960 | 3,790 | 7.6 |
| -2 | 16,370* | 14,520 | 13,470* | 9,210 | 10,850* | 6,730 | 8,600 | 5,300 | 6,920 | 4,360 | | | 6,440 | 4,070 | 7.2 |
| -3 | 16,090* | 14,650 | 12,710* | 9,280 | 10,310* | 6,780 | 8,480* | 5,340 | | | | | 7,320 | 4,590 | 6.6 |
| -4 | 14,190* | 14,190* | 11,320* | 9,430 | 9,150* | 6,880 | | | | | | | 7,940* | 5,750 | 5.6 |

STANDARD EQUIPMENT

ENGINE SYSTEM

- Cummins diesel engine, turbocharged, inline 6-cylinder, 4 stroke, water cooled
- Auto-idle speed control
- Air filter with pre-cleaner
- Engine oil filter
- Pre-filter with water separator
- Radiator, oil cooler and intercooler
- IPC (Intelligent Power Control) System
- Engine overheating prevention system

DRIVETRAIN

- Hydraulic motor, one-piece two-gear piston and reducer
- 2-speed travel system with automatic shift

SWING SYSTEM

- High-torque piston swing motor with integral spring set and automatic hydraulic release swing brake

HYDRAULIC SYSTEM

- Main pump: two variable displacement piston pumps, ready for PTO
- Pilot pump: gear
- Cylinders: boom, arm, bucket
- Power boost function
- Boom and arm regeneration circuits
- Pilot oil filter
- Load holding valve
- Pilot control shut-off lever
- Hose burst safety valves, prevention of boom or arm supply dropped when the lines split (2 mounted on boom cylinders, 1 on arm cylinder)
- 6-working mode selection system: Power, Economy, Fine, Lifting, Breaker, Attachment

DIGGING EQUIPMENT

- 5,710 mm boom
- 2,915 mm arm
- 0.9 m³/1 m³ (SAE, heaped) bucket
- Counterweight, 4,000 kg

OPERATOR STATION

- Pressurized and sealed cab with all-around visibility, large roof window with slide sliding sun visor, front window wiper and removable lower window
- Roll-Over Protective System (ROPS)
- Skylight rooftop
- Air conditioner, heater, defroster
- Swing parking brake
- AM/FM radio with MP3 audio jack
- Glass-breaking hammer
- Ashtray, cigarette lighter
- Cup holder
- Floor mat
- Storage box
- Front glass lower guard
- Fire extinguisher
- Rear view mirrors
- One key for all locks

INSTRUMENTATION

- Color LCD monitor with alarms, filter/fluid change, fuel rate, water temperature, work mode, fault code, working hour, etc.
- Fuel gauge
- Hydraulic oil level gauge

ELECTRICAL

- Alternator 70 A
- Dual batteries 2 x 12 V
- Working lights, 1 frame mounted, 2 boom mounted
- Rotating beacon
- Starting, 24 V

UNDERCARRIAGE

- 600 mm track-shoes with triple grousers
- 2 piece track-guards (each side)
- Towing eye on base frame

GUARDS

- Belly guards
- Cover plate under travel frame
- Track shields

OTHER STANDARD EQUIPMENT

- Maintenance tool kit
- Maintenance parts package

OPTIONAL EQUIPMENT

ENGINE SYSTEM

- Electrical fuel refilling pump

HYDRAULIC SYSTEM

- Hydraulic attachments rotation lines
- Over loading warning
- Hose burst safety valves, prevention of boom or arm supply dropped when the lines split.
- Dual way auxiliary lines
- Quick coupler lines (low and high pressure)

OPERATOR STATION

- Operation protection guard (included cab front and top guard, bar)
- Operation protection screen (on cab front, net)
- Operation protection screen (front-lower)
- Roll-Over Protective System (ROPS)
- Rain visor
- Mechanic heated suspension seat
- Air suspension seat

ELECTRICAL

- LED working lights on cab, 4 front and 2 rear
- Rear view camera
- Travel alarm
- Rotating beacon

UPPERSTRUCTURE

- Belly guard and 8 mm thickness platform bottom plate
- Bucket cylinder guard

UNDERCARRIAGE

- 700 mm, 800 mm, 900 mm track-shoes with triple grousers
- 3 piece track-guards (each side)

DIGGING EQUIPMENT

- Arm: 2,700 mm
- Bucket: 0.9/0.95/1.0/1.1
- Hydraulic hammers (LiuGong & Soosan)
- Hydraulic quick coupler
- Quartered grapple



Guangxi LiuGong Machinery Co., Ltd.

No. 1 Liutai Road, Liuzhou, Guangxi 545007, PR China
T: +86 772 388 6124 E: overseas@liugong.com
www.liugong.com

Like and follow us:



LG-PB-920E-T2-20-042020-ENG

The LiuGong series of logos herein, including but not limited to word marks, device marks, letter of alphabet marks and combination marks, as the registered trademarks of Guangxi LiuGong Group Co., Ltd. are used by Guangxi LiuGong Machinery Co., Ltd. with legal permission, and shall not be used without permission. Specifications and designs are subject to change without notice. Illustrations and pictures may include optional equipment and may not include all standard equipment. Equipment and options varies by regional availability.