



VIBRATORY HAMMER

OVH series

The best solution for civil,
municipal, bridge, cofferdam,
foundation and etc.

High pressure washable hydraulic oil filter

Swivel system & Hydraulic motor
360° full return swivel structure,
IP66 waterproof and dustproof,
very stable and reliable

Hydraulic valve block
Waterproof
solenoid and adapter

Breather
Balances the air
pressure and
heat in gear box

Hydraulic control system
Special designed for
vibratory hammers.

High quality hydraulic motor

Electric control system
High quality water proof connectors
and special designed control box.

Clamp
Cast steel body

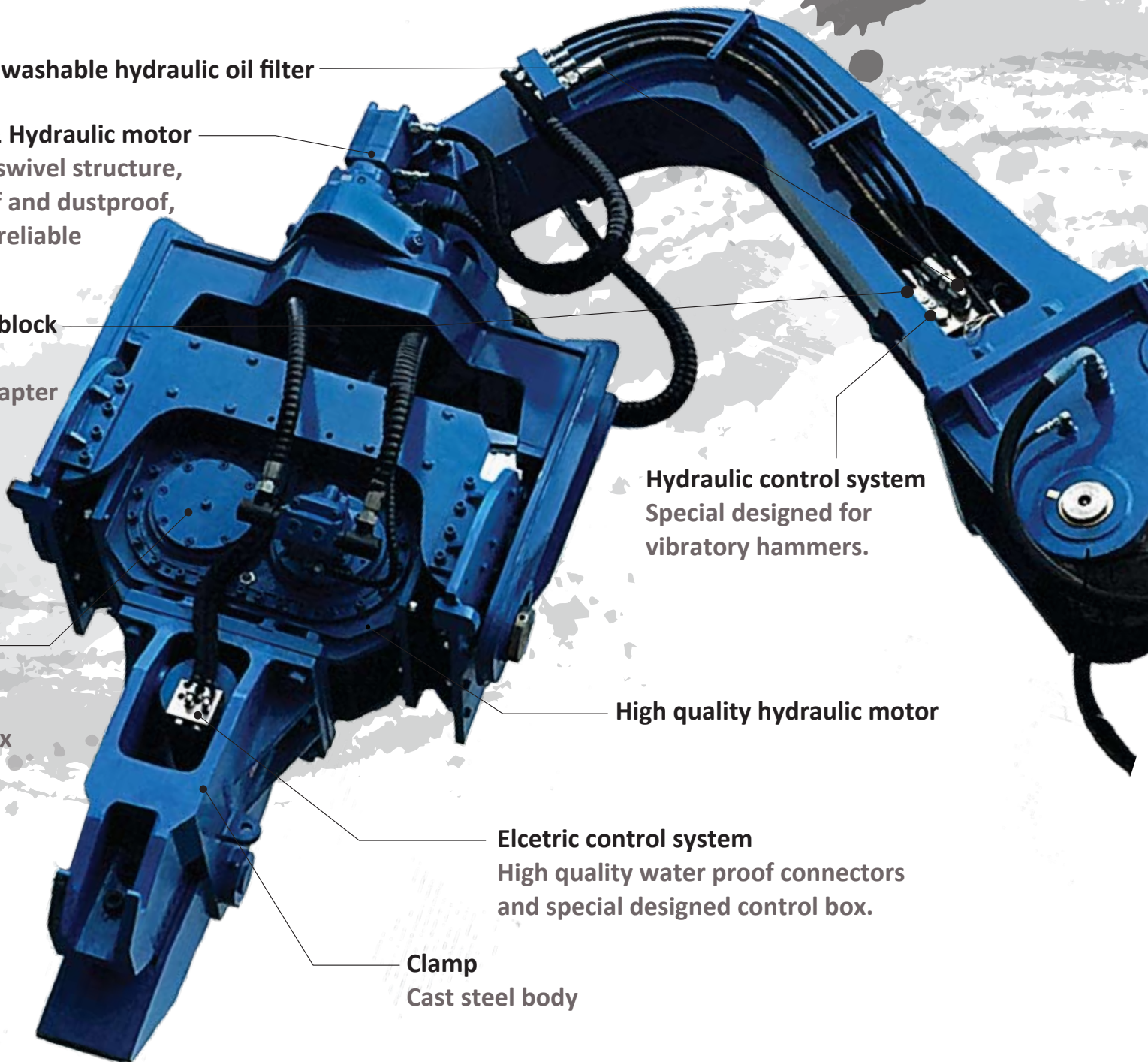

Clamp



C17
For H-beam/Sheet pile



C19
For Sheet pile



C12G
For tube



C30B
For Concrete pile
(Cubic pile)



C35E
For Concrete pile
(Column pile)

Accessory



Cubic sleeve



Drill rod
1.5/3.0m



Column sleeve
Φ300/400 mm



Drill rod
1.5/3.0m



Column sleeve
Φ300/400 mm



Auger
Φ300*1.5m

Specifications

		OVH250	OVH320	OVH400	OVH480	
Max. frequency	rpm	3000	3000	3000	3000	
Eccentric force	ton	46.2	51.3	56.5	61.6	
Swivel torque	Nm	9200		11000		
Swivel speed	rpm	12				
Max. working pressure	bar	315				
Oil flow	lpm	189	240	240/270	270/324	
Driver weight	ton	1.7	1.8	2.15	2.2	
Clamp		C17,C30B		C19,C35E		
Weight	kg	C17:520, C19:550, C30B:455, C35E:530				
Gooseneck arm		A200C(K), A250C, A300C, A350C				
Gooseneck arm weight	kg	A200C:750, A200CK:750, A250C:850, A300C:950, A350C:1100				
Size	A	mm	2485	2485	2586	2586
	B	mm	1245	1245	1460	1460
	C	mm	737	737	737	737
Suitable carrier range	ton	20~25	27~35	35~45	40~50	

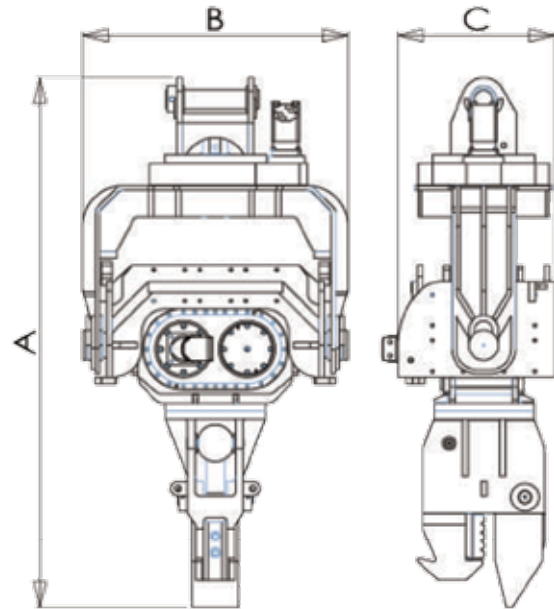

OKADA AIYON CORPORATION

www.okada-aiyon.com

4-1-18, Kaigan-dori, Minato-ku, Osaka 552-0022, Japan

Tel +81-(0)6-6576-1268 Fax +81-(0)6-6576-1516

Email sales@aiyon.co.jp

facebook.com/okadaaiyon

youtube.com/OkadaAiyonCorp

